



AIRSENTINEL™ BYPASS HEPA FILTRATION SYSTEM

AirSentinel™ Bypass HEPA (High Efficiency Particulate Arrestance) filters are used in hospitals because they are considered the best filters on the market today. HEPA filters were originally developed by the Atomic Energy Commission during World War II to remove hazardous radioactive dust from manufacturing plant exhaust. In order to receive a HEPA filter designation, a filter must collect 99.97% of a specific particulate that measures 0.3 microns in size, in tests established by the Institute of Environmental Sciences. The HEPA system is 99.97% at .3 microns and removes particles as small as .01 microns.

HEPA systems usually require a significant amount of fan energy to force air through the filtration media. The Bypass HEPA Filtration System (300 CFM) system overcomes this requirement by positioning the system parallel to, instead of across, the airstream. Polluted air is directed through the filter on multiple passes to cleanse the air. Working in combination with a pre-filter to capture larger particles, the system is designed to operate at peak performance for up to two years before requiring replacement of the HEPA filter.



120V/1/60Hz

Features

Safe & Quiet Operation

- Quiet, compact, and lightweight design.
- The motor pulls air through the pre-filter as it pushes air through the carbon and HEPA media filter to effectively isolate sounds from moving air and the motor.
- The entire cabinet is thermally insulated to provide even quieter operation.

Variable Speeds

- Two-speed, maintenance-free, PSC motor has been pre-lubricated for the motor's life.

HEPA Rated

- Pleated pre-filter is 30% efficient – to capture large particles.
- EDGE activated carbon pre-filter is 30% efficient to capture large particles and absorbs normal household odors.
- HEPA filter is 99.97% efficient to filter particles down to 0.01 microns in size.
- CSA certified

Easy to Maintain

- Easy access front access door.
- Motor switch will automatically shut off the motor when door is opened for safe filter replacement.
- HEPA filter should be replaced every two years.
- EDGE activated carbon and pre-filters should be replaced twice annually.

Flexible Installation

- Can be duct-mounted or collar mounted to adapt to any type of heating and cooling system.

Warranty

- Seven (7) Year Limited Warranty.

Optional Accessories

- Collar Mount adapter kit.

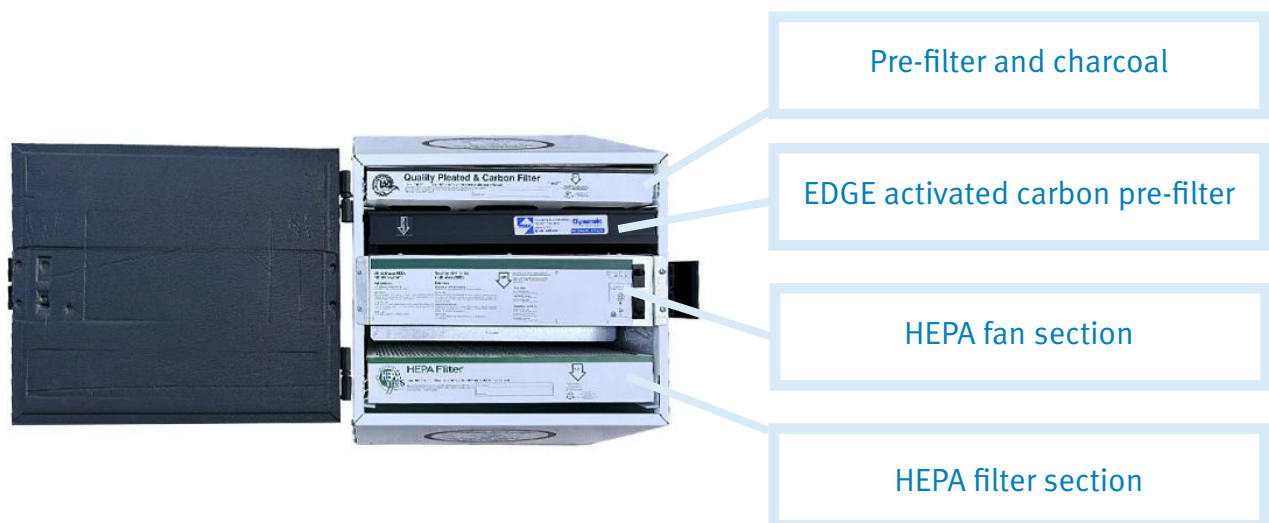

Website: ElevatedIndoorAir.com

Phone: (239)-ELE-VATE (353-8283)

SPECIFICATIONS

Unit Weight	28 lbs (12.7 kg)
Cabinet Dimensions	17"W x 22"H x 11.6"D
Opening Size Plenum Mount	16"x3.5" (40.6 cm x 8.9 cm)
Opening Size Collar Mount	8" (20.3 cm) Round *
Installation Type	Plenum, Wall or Floor Mount
Electrical Input	120VAC @ 60 Hz
Power Consumption	134 Watts
Airflow	220 CFM (low) 300 CFM (high)

PART NUMBERS & ACCESSORIES

Description	Part No.
300 CFM Bypass HEPA	xxx-HP-300
8" Collar Mount Adapter Kit	CMK500
Replacement HEPA filter	RHF562
Annual pre-filters (2) replacement kit	ARK564
Replacement power cord	PWRC60
Replacement motor assembly	2RREU25

Typical Installations

Stand-Alone Attic

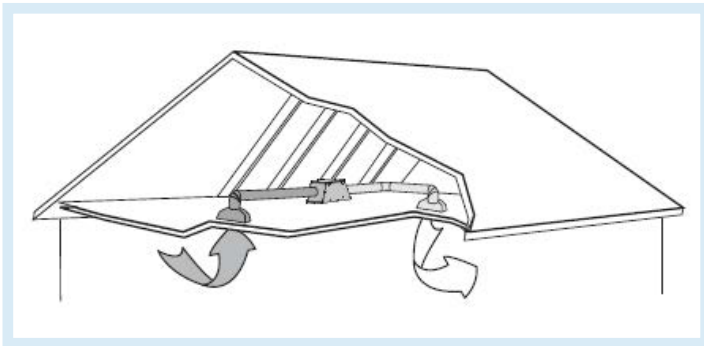

Stand-Alone Basement

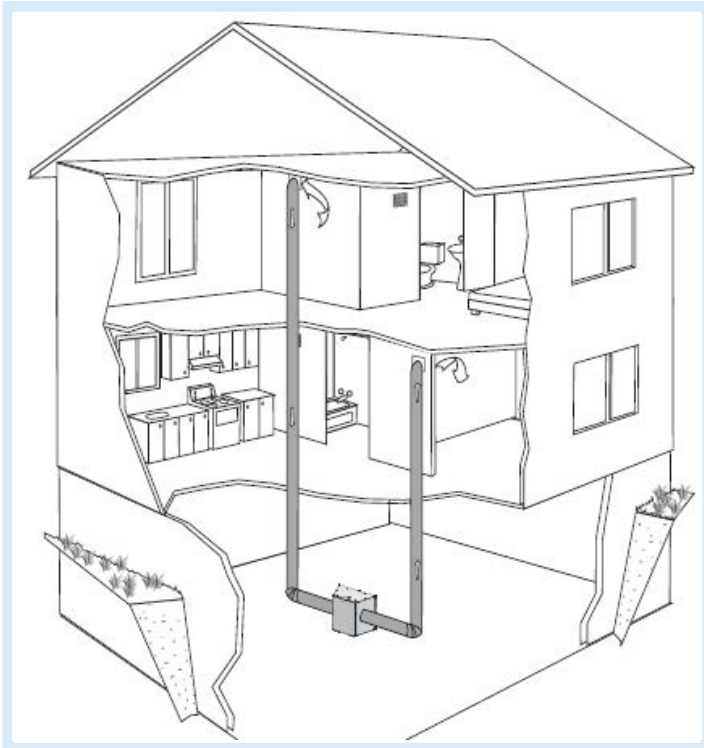

Ducted System

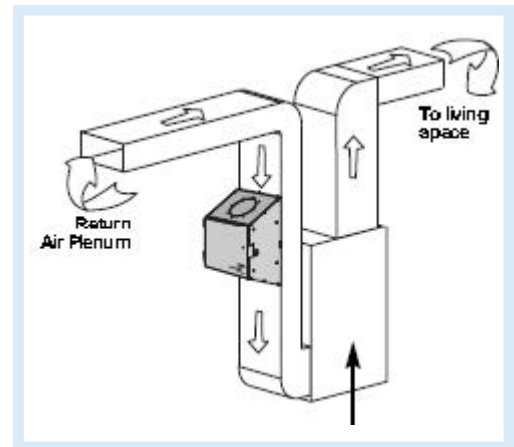

Collar System

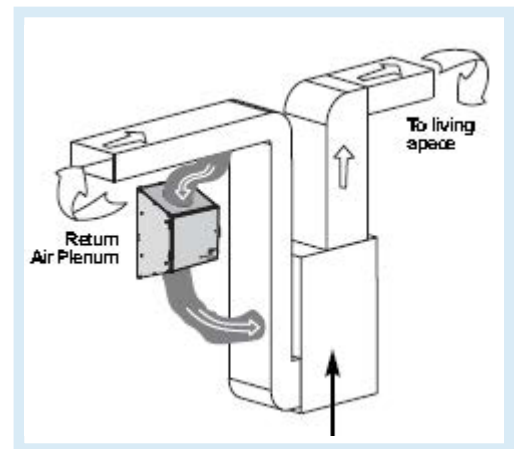

Specifications subject to change without notice.
©2024 Dynamic Air Quality Solutions

Website: [ElevatedIndoorAir.com](https://www.ElevatedIndoorAir.com)

Phone: (239)-ELE-VATE (353-8283)

ELE-SPEC-472 06/24